

Articulated cradles are specially designed for access to recessed facades. Two models have currently been standardised, one for a **recess of 2 meters (AC-2)** and one for a **recess of 3 meters (AC-3)**.

The articulated cradles are designed for use with SENIOR Building Maintenance Unit equipment. The cradles are opened and closed using a double-acting hydraulic ram. The hydraulic pump is controlled manually from the cradle.

Please contact our Engineering Department for additional information (most appropriate model for the application concerned, counterweights to use, prices, etc).

Model	Distance between suspension rope and foam roller (mm)	Weight (±kg)
AC-2	2.080	400
AC-3	3.083	680

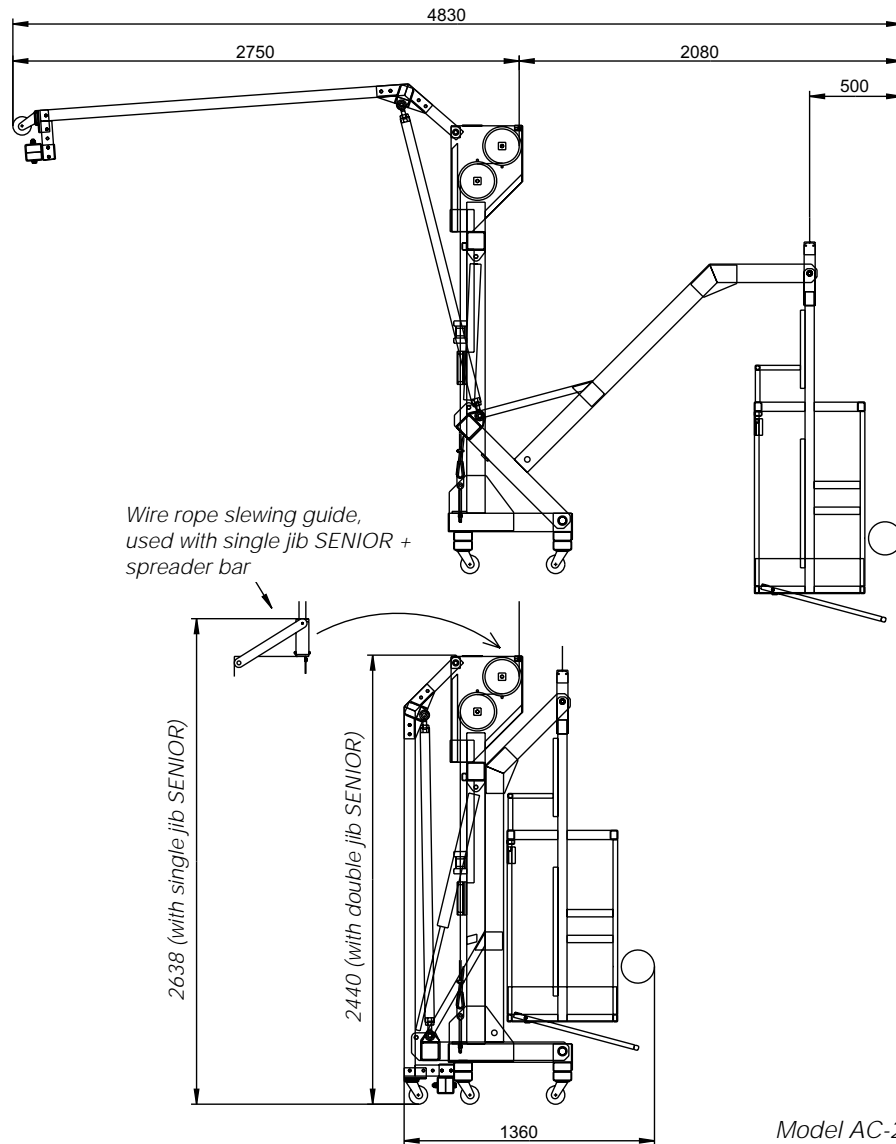

Model AC-3

